

World Class Power Solutions

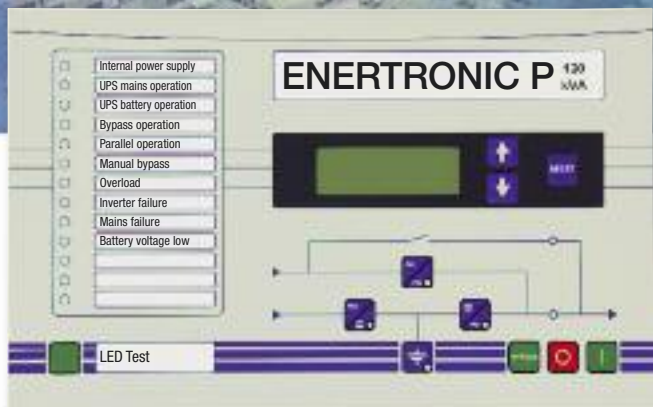

**Industrial UPS,  
three phase output**

**ENERTRONIC P Range**



## ENERTRONIC P disposed for highest security

### General

The requirement for power supply reliability is growing, due to the increasing application of information and data carrier systems, text processing, automated production processes and complex data networks.

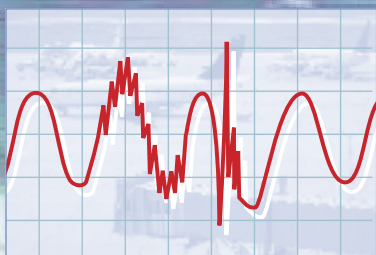
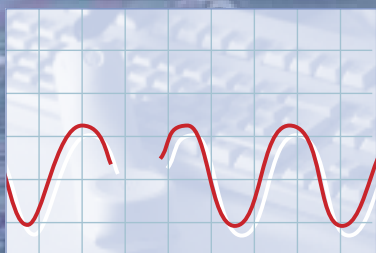
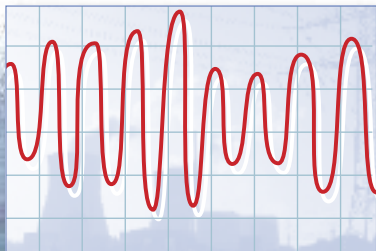

Fig. 1: Possible Irregularities

Irregularities due to loading of the public power supply by major users, peak-time use or by lightning strikes cannot be avoided.

The result is:

Mains voltage breaks, spikes and transients. (Fig. 1)

Static UPS's are being installed increasingly for loads that require AC voltages unaffected by interference on the mains e.g.

- Data processing installations
- Process control computers
- Air safety installations
- Signalling, alarm systems
- Telecommunication systems
- Power- and Substations



Fig. 2: ENERTRONIC P UPS

### Design

Due to the use of IGBT transistors of the newest technology in the rectifier and in the inverter, the new ENERTRONIC P range fulfills the highest reliability for power supplies and is very economical.

This results in an input power factor of  $\geq 0,99$  and an input distortion factor of  $< 5\%$ .

The exceptional characteristics of this inverter in the ENERTRONIC P series results in very small dynamic voltage deviations even in the case of one hundred percent load changes.

A combination of a 16-bit micro-controller and the latest power electronics is responsible for controlling and monitoring of all rectifier, inverter and static switch functions with highest reliability. A static switch and a manual bypass switch are integrated in the unit.

In the front of the cabinet there is a plastic foil keyboard with 6 keys, 4 three coloured and 2 single coloured LED's and a mimic diagram.

# ENERTRONIC P *multi utilities*

## Static Bypass

The static bypass of the UPS facilitates uninterrupted change-over to direct mains supply (bypass mains), keeping within the specified tolerances. The change-over can be initiated manually or automatically by a control signal. The  $\mu P$  monitoring is autonomous and prevents incorrect operation of the UPS and any illogical switching functions of the static bypass.

Thus, for example, an uninterrupted change-over, whether automatic or manual, is only possible when the voltage, frequency and phase conditions of the inverter are synchronised with the bypass mains. Mains frequency deviations, which lie outside the preset tolerances cause blocking of the change-over, or if the inverter fails, a change-over with an interruption.

A change back can only occur to a functioning inverter, and is in every case uninterrupted even if the mains should fail on a test change-over.

The static bypass consists of a microprocessor-controlled anti parallel thyristor block. It can be activated manually with a push button, in order to test the change-over. The change-over from inverter to the mains and back takes place in a synchronised operation without a break.

The static bypass has an overload capability of 150 % for 10 min. and 1000 % (three phase output) for 100 ms. After the presence of an overload or a short-circuit, it automatically resets the load to the inverter, if normal operation is possible.

## Parallel Operation

For redundancy or increased output power, up to eight ENERTRONIC P units can be connected in parallel, operating in an active load-sharing mode with active and passive master.

Half load parallel operation is achieved using two separate bus bars, connected with a coupling switch. The state of the coupling switch is relayed to the microprocessor, via an auxiliary contact.

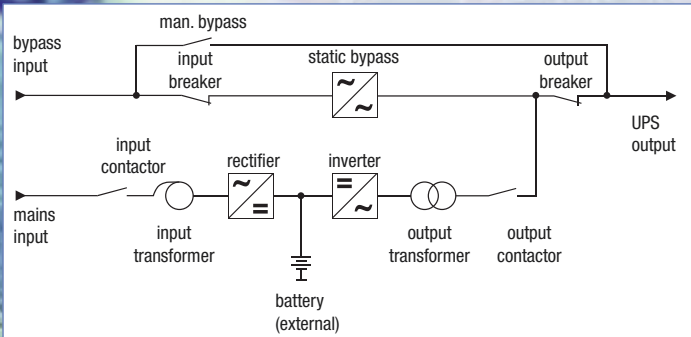

Fig. 5: Block diagram

## Internal manual bypass

Each UPS is equipped with a maintenance bypass with manually operated switch. When operated, the ENERTRONIC P is completely disconnected from the load. The supply to the load is now directly from the mains via the manual bypass. (Fig. 5)

## Option

For power plant applications where higher than normal fault three phase clearing current is required, it is possible to specify an option for 4 x I nominal system output. Depending on the output power, a bigger cabinet may be required.

## Front Panel

The operation of the UPS is made by a plastic foil keyboard with 6 keys, 4 three coloured and 2 single coloured LED's. There is a mimic diagram on the operating section. The operating condition and any operational disturbances are represented by the multi colour LED's. (Fig. 6)

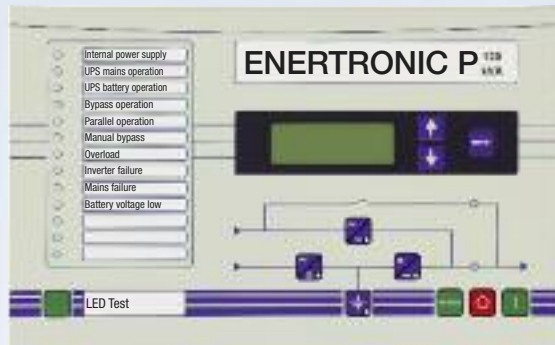

Fig. 6: Front Panel

There is a 4-line, 80-digit LC display in the operating section for reading information and/or for clear guidance by the menu. Control of the operating section takes place via the display controller, which communicates over the CAN bus with the controller board.

In addition, the most important operating and fault signals are indicated by 13 single LED's.

### Rectifier:

- input voltage
- input current of each phase (each phase/phase or phase/neutral conductor)
- frequency

### Inverter:

- output voltage (with three phase output phase/phase or phase/neutral conductor)
- output current (with three phase output of each phase)
- apparent power
- frequency
- real power



# ENERTRONIC P

remote management - proofed and convenient

### Parallel Handling

A UPS system provides security for a critical application. Purchasing a parallel redundant system, provides even further security. Consequently it is necessary to consider parallel systems as a single unit. Critical measurements, such as battery autonomy are calculated and expressed for the combined system.

A shutdown is not initiated until the parallel system is unable to deliver the load current demanded. Major system alarms are not activated unless the situation has reached a critical state. This functionality can be realised using different Power Management Solutions and Software Packages.

### Power Management Solutions

- Environmental Monitoring
- Integration in Network Management System
- Integration in building Management System
- ModBus interface
- ProfiBus interface
- Remote Monitoring System through WEB
- Remote Monitoring System with SNMP
- Redundant UPS Monitoring
- Integration in Multivendor/ Multiplatform environments
- Extensive alarm handling/ Dispatching

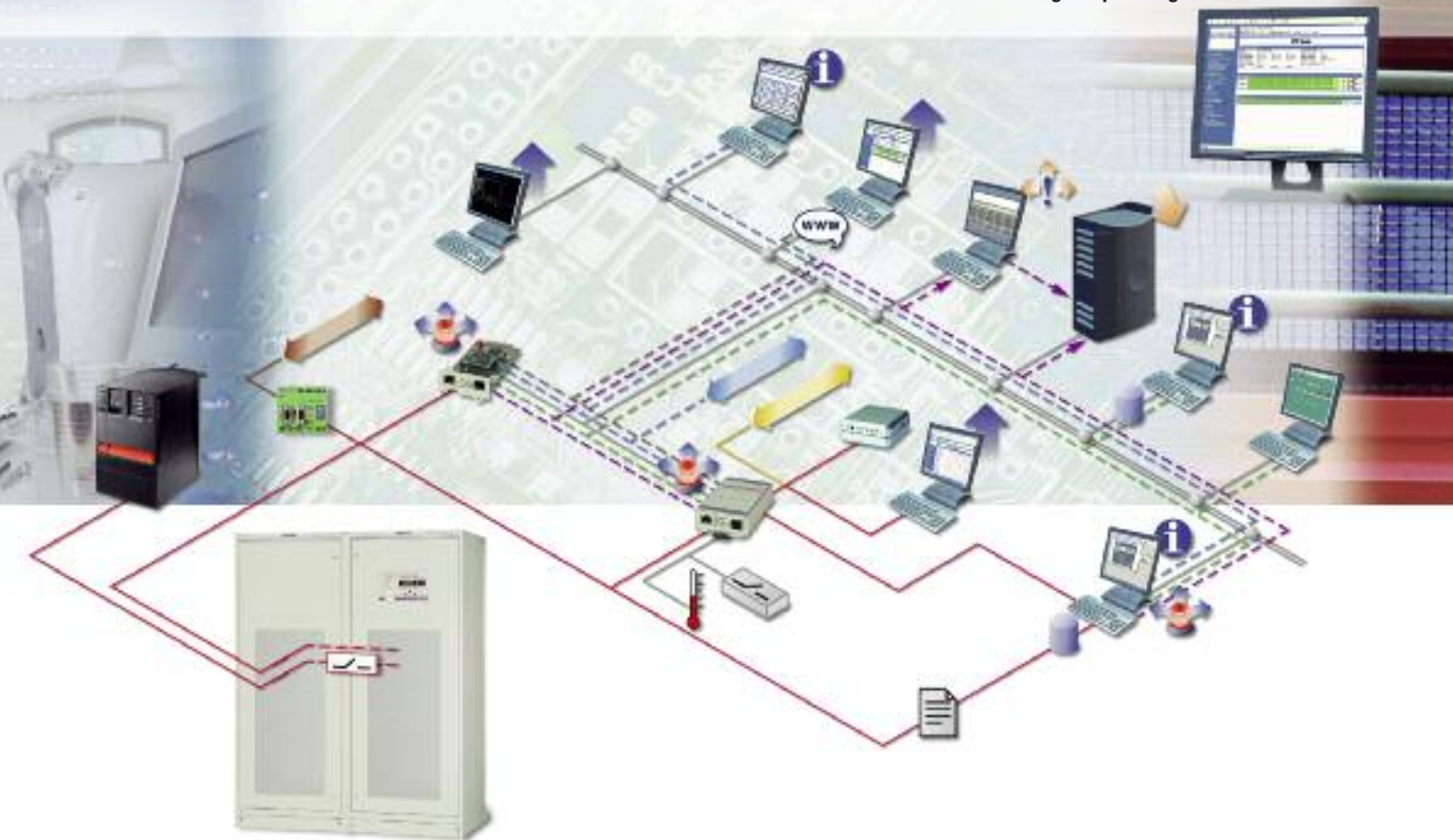

### UPSMAN/UPSMON – CS121 Web / Adapter UPS functions

UPS-Management software for Windows 95/98/2000/NT/XP®	UPS-Management software for Novell NetWare®	CS121 – SNMP Web Manager®	UPS-Management software for Unix®/Mac OS® systems
UPS – Standard functions/warning e.g. battery low/power failure/overload/UPS connection restored/System shutdown			
UPS – Extended functions/warnings e.g. Inverter overload/Fuse blown/Rectifier mains fault/Inverter feeding/Battery switch open			
UPS – send UPS shutdown signal			
UPS – SNMP redundancy capability (USW software)			
Graphic display UPSMON/HTML/JAVA			
Environmental monitoring – Facility management e.g. BENNING Sitemanager, Sitemonitor, Tempman, Siteswitch	—	Environmental monitoring – Facility management e.g. BENNING Sitemanager, Sitemonitor, Tempman, Siteswitch	—

# ENERTRONIC P

## technical data

### Technical Data

ENERTRONIC P 3-3 with three phase input and three phase output - DIN Type: D400 D400/...../2 rfg-UDG....

Nominal power cos.  $\varphi$  0,8: [kVA] 60, 80, 120

#### Type ENERTRONIC P

UPS Nominal output power (cos. $\varphi=0,8$ ind.):	[kVA]	60	80	120
---	-------	----	----	-----

#### Type ENERTRONIC P

Max. input power:	[kVA]	66	88	129
Nominal input power without battery charging:	[kVA]	58	75	108
Nominal input current without battery charging (at 400 V):	[A]	84	109	156
Max. input current with high rate charging (at 400 V):	[A]	96	127	186
Transformer:		autotransformer (optional galvanically isolated)		
Input power factor:	[cos. $\varphi$ ]	$\geq 0,99$ ( 0,97 already at 25% load )		
Nominal input voltage:	[V]	3/N 400 V $\pm$ 15%		
Nominal input frequency:	[Hz]	50 Hz $\pm$ 5%		
Mains distortion (at 100% load):	[%]	$\leq 5$		
Current ripple:		$< 5$ A / 100 Ah		

#### Battery data

Recommended number of battery cells:			180 - 204	
Max. charging current:	[A]	26	34	52

#### Inverter data ENERTRONIC P 3-3

Inverter input voltage:	[V]	317 - 470		
Nominal input real power (with load cos. $\varphi=0,8$ ind.):	[kW]	49	65.5	98
Nominal output real power (cos. $\varphi=1$ ):	[kW]	48	64	96
Nominal output current (cos. $\varphi=0,8$ ):	[A]	87	116	173
Nominal output current (cos. $\varphi=1$ ):	[A]	70	92	139
Nominal output voltage:	[V]	3/N 400 V (adjustable $\pm$ 5%)		
Nominal output frequency:	[Hz]	50		
Transformer:		galvanically isolated		
Voltage tolerance:				
- static	[%]		$\pm 1$	
- 50% asymmetric load	[%]		$\pm 1$	
- 100% asymmetric load	[%]		$\pm 3$	
- dynamic with 100% load change	[%]		$< 5$	
Regulation time:	[msec]		$< 10$	
Angle deviation:				
- symmetric load			$< 1^\circ$	
- 50% asymmetric load			$< 2^\circ$	
- 100% asymmetric load			$< 3^\circ$	
Frequency tolerance: - mains synchronised	[%]		$\pm 1$ (synchronisation range $\pm 4$ )	
- self synchronised	[%]		$\pm 0.1$	
Distortion factor (acc. EN 62040-1): - linear load	[%]		$< 1$	
- non linear load	[%]		$< 5$	
Crest factor:			$\geq 3$	
Overload: - 3ph	[%]		150% 60 sec., 125% 10 min.	
- 1ph / N	[%]		220% 60 sec., 180% 10 min.	
Short-circuit behaviour: - 3ph	[%]		200% 3 sec.	
- 1ph / N			350% 3 sec.	
			Inverter itself is short circuit proof, switch OFF after max. 3 seconds if bypass mains is not available (EN 62040)	
Inverter efficiency with nominal load (cos. $\varphi$ 0,8):	[%]		$\geq 94$	

# ENERTRONIC P

## general data

Technical Data				
<b>Type ENERTRONIC P</b>				
UPS Nominal output power (cos. $\varphi=0,8$ ind.):	[kVA]	60	80	120
<b>General data</b>				
Over all efficiency (AC to AC) without battery charging:				
- 100% load		92	92	92
- 75% load		92	92	92
- 50% load		91	91	91
- 25% load		89	89	89
Heat dissipation: - 100% load	[kW]	4.7	5.9	8.3
- 0% load	[kW]	2.3	2.3	3.2
Noise level with 1 m distance:	[dB (A)]	≤63		≤65
Permitted ambient temp.:	[°C]	0 to +40 (daily average ≤ 35)		
Relative humidity:	[%]	5 - 95 without condensing		
Permitted installation height:	[m]	< 1000 m above sea level without derating		
Humidity class:		DIN/IEC 721 2-1-09/86		
Protection degree:		IP 20 (DIN/VDE 0470 part 11/92 IEC 529) / others optional		
Radio interference:		EN 50091-2 standard class A (optional class B)		
Dimensions: (Width)	[mm]	800		
(Depth):	[mm]	800		
(Height):	[mm]	2000 (optional 2200 height)		
Weight:	[kg]	900	900	1100
Cooling: forced cooled with speed controlled, redundant and monitored fans, build in the air inlet, equipped with air flaps, which close in case of fan failure, fans can be changed from front, power blocks and transformers are temperature monitored, prewarning will be sent out, after temperature increase switch OFF, air inlet from front, air outlet from top				
Cable entry:		from bottom (optional from top with cable cabinet, width 200 mm)		
Painting:		RAL 7035, structured power coating		
<b>Static bypass</b>				
Nominal voltage:	[V]	400 / 230		
Nominal frequency:	[Hz]	50		
Over load: - 10 min.	[%]	150		
- 100 msec.	[%]	1000		
Transfer limits:	[%]	U ± 10; F ± 5		
Inverter/Bypass transfer time:				
- inverter failure	[msec]	< 1		
- overload or manual transfer	[msec]	< 1		
interlock when transfer was activated 5 times within a minute				
Bypass/inverter transfer time:	[msec]	< 1		
<b>Other options</b>				e.g. bypass transformer on request.

**Battery:**

- voltage
- remaining back up time
- charge/discharge current
- remaining capacity

**Bypass:**

- input voltage (with three phase output phase/phase or phase/neutral conductor)
- input current (with three phase output of each phase)
- frequency

An event recorder stores each occurring event (push button operation, switching events and error) with date and time. Up to 1200 entries can be stored.

The following information is indicated via 6 volt free change over contacts:

- mains operation (mains OK)
- manual bypass activated
- battery operation
- low battery voltage
- bypass operation
- common alarm

As serial interfaces a RS232 and RS485 each with MODBUS protocol is provided as standard, additionally an analogue output with 0 or 4 to 20 mA is included which can be programmed with an internal value, e.g. output power.

**Digital inputs:**

- EMERGENCY POWER OFF (EPO)
- remote ON/OFF
- inhibit battery charging
- generator operation
- inhibit bypass operation

As an option an additional relay card with 6 relays and an additional interface card with a RS232 and RS485 can be build in, also a Profibus interface and network interface (TCP/IP) can be added.

# ENERTRONIC P

## an uninterruptible power supply

### Function

The static UPS not only has the task of supplying the connected consumers continuously and without interruption, but beyond that to also provide a clear improvement of the voltage and frequency quality in relation to the normal system. In normal operation the load is supplied by the input autotransformer, rectifier, inverter and output transformer route.

The ENERTRONIC P is designed to meet the highest UPS classification VFI SS 111 in accordance with EN 62040-2.

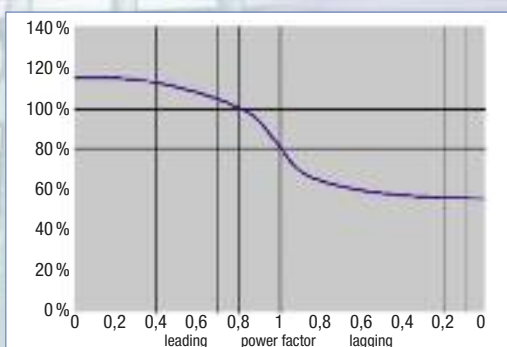

Fig. 3: Available UPS apparent output power depending on power factor



Fig. 4: Interior view

### Rectifier

The rectifier consists of an IGBT bridge with power factor correction (power factor = 1), converting the three phase mains voltage via an autotransformer (optional isolated transformer) into a controlled DC voltage to supply the inverter and to recharge the connected battery or to keep the battery in optimum capacity in float charge condition.

The rectifier is able to supply the fully loaded inverter and to recharge the discharged battery to 95 % of its capacity within 12 hours.

The rectifier is equipped with a software controlled soft start to start the rectifier on a ramp after mains failure.

The restart of parallel systems is done in steps so that not all UPS's are starting at the same time.

The rectifier is also equipped with an IU charging characteristic in accordance with the information of the battery manufacturer, with the option of battery temperature compensation.

### Inverter

The inverter power block changes DC voltage into a single or three phase sinusoidal AC voltage with constant amplitude and stable frequency. The output voltage is independent of line disturbances or power failures.

The unit works with an IGBT inverter bridge with pulse width modulation having a high efficiency in the partial load range as well as achieving a low distortion factor at non linear load.

In the event of mains interruption or failure, the battery connected to the DC input is brought in automatically and without interruption to supply current. If the battery becomes discharged this is reported. If the battery discharge limit is exceeded, the inverter automatically turns off and a warning is given shortly before the discharged voltage limit is reached.

Automatic change-over of the load to the bypass mains or a suitable spare supply occurs if the supply from the inverter falls outside the preset tolerances.



[www.benning.de](http://www.benning.de)

## BENNING worldwide

### Austria

Benning GmbH Elektrotechnik und Elektronik  
Eduard-Klinger-Str. 9  
A-3423 St. Andrä-Wördern  
Tel. 0 22 42 / 3 24 16-0  
Fax 0 22 42 / 3 24 23  
E-Mail: [info@benning.at](mailto:info@benning.at)

### Belarus

IOOO BENNING Belarus  
ul. Derzinskogo, 50  
BY-224030, Brest  
Tel. 0162 / 22 07 21  
Fax 0162 / 22 07 21  
E-Mail: [info@benning.brest.by](mailto:info@benning.brest.by)

### Belgium

Benning Belgium  
Power Electronics  
Z. 2 Essenestraat 16  
B-1740 Ternat  
Tel. 02 / 58 287 85  
Fax 02 / 58 287 69  
E-Mail: [info@benning.be](mailto:info@benning.be)

### Croatia

Benning Zagreb d.o.o.  
Trnjanska 61  
HR-10000 Zagreb  
Tel. 1 / 63 12 280  
Fax 1 / 63 12 289  
E-Mail: [info@benning.hr](mailto:info@benning.hr)

### Czech Republic

Benning CR s.r.o.  
Zahradní ul. 894  
CZ-293 06 Kosmonosy  
(Mladá Boleslav)  
Tel. 3 26 72 10 03  
Fax 3 26 72 25 33  
E-Mail: [benning@benning.cz](mailto:benning@benning.cz)

### France

Benning Conversion d'énergie  
43, avenue Winston Churchill  
B.P. 418  
F-27404 Louviers Cedex  
Tél. 0 / 2.32.25.23.94  
Fax 0 / 2.32.25.08.64  
E-Mail: [info@benning.fr](mailto:info@benning.fr)

### Germany

Benning Elektrotechnik und Elektronik  
GmbH & Co.KG  
Factory I: Münsterstr. 135-137  
Factory II: Robert-Bosch-Str. 20  
D-46397 Bocholt  
Tel. 0 28 71/ 93-0  
Fax 0 28 71/ 9 32 97  
E-Mail: [info@benning.de](mailto:info@benning.de)

### Great-Britain

Benning Power Electronics (UK) Ltd.  
Oakley House  
Hogwood Lane  
Finchampstead  
GB-Berkshire  
RG 40 4QW  
Tel. 0118 9731506  
Fax 0118 9731508  
E-Mail: [info@benninguk.com](mailto:info@benninguk.com)

### Hungary

Benning Kft.  
Power Electronics  
Rákóczi út 145  
H-2541 Lábattán  
Tel. 033 / 50 76 00  
Fax 033 / 50 76 01  
E-Mail: [benning@vnet.hu](mailto:benning@vnet.hu)

### Italy

Benning Conversione di Energia S.r.L.  
Via 2 Giugno 1946, 8/B  
I-40033 Casalecchio di Reno (BO)  
Tel. 0 51 / 75 88 00  
Fax 0 51 / 61 67 655  
E-Mail: [info@benningitalia.com](mailto:info@benningitalia.com)

### Netherlands

Benning NL  
Power Electronics  
Peppelkade 42  
NL-3992 AK Houten  
Tel. 0 30 / 6 34 60 10  
Fax 0 30 / 6 34 60 20  
E-Mail: [info@benning.nl](mailto:info@benning.nl)

### Poland

Benning Power Electronics Sp. z o.o.  
Korczyńska 30  
PL-05-503 Głusków  
Tel. 0 22 / 7 57 84 53  
Fax 0 22 / 7 57 84 52  
E-Mail: [biuro@benning.biz](mailto:biuro@benning.biz)

### P. R. China

Benning Power Electronics (Beijing) Co., Ltd.  
Tongzhou Industrial Development Zone  
1-B BeiEr Street  
CN-101113 Beijing  
Tel. 010 61568588  
Fax 010 61506200  
E-Mail: [info@benning.cn](mailto:info@benning.cn)

### Russian Federation

OOO Benning Power Electronics  
Moscow region,  
Domodedovskiy district,  
Domodedovo, Severny zone,  
Tel. (495) 967 68 50  
Fax (495) 967 68 51  
E-Mail: [benning@benning.ru](mailto:benning@benning.ru)

### Slovakia

Benning Slovensko, s.r.o.  
Kukuričná 17  
SK-83103 Bratislava  
Tel. 02 / 44459942  
Fax 02 / 44455005  
E-Mail: [benning@benning.sk](mailto:benning@benning.sk)

### South America

Benning Office South America  
Lavalle 637  
AR-1876 Bernal, Buenos Aires  
Argentina  
Tel. 54/ 911 5498 2515  
E-Mail: [info-argentina@benning.es](mailto:info-argentina@benning.es)

### South East Asia

Benning Power Electronics Pte Ltd  
85, Defu Lane 10  
#05-00  
SGP-Singapore 539218  
Tel. (65) 6844 3133  
Fax (65) 6844 3279  
E-Mail: [sales@benning.com.sg](mailto:sales@benning.com.sg)

### Sweden

Benning Sweden AB  
Box 990, Hovslagarev. 3B  
S-19129 Sollentuna  
Tel. 08 / 6239500  
Fax 08 / 969772  
E-Mail: [power@benning.se](mailto:power@benning.se)

### Switzerland

Benning Power Electronics GmbH  
Industriestrasse 6  
CH-8305 Dietlikon  
Tel. 044 / 8057575  
Fax 044 / 8057580  
E-Mail: [info@benning.ch](mailto:info@benning.ch)

### Spain

Benning Conversión de Energía S.A.  
C/Pico de Santa Catalina 2  
Pol. Ind. Los Linares  
E-28970 Humanes, Madrid  
Tel. 91 / 6048110  
Fax 91 / 6048402  
E-Mail: [benning@benning.es](mailto:benning@benning.es)

### Ukraine

Benning Power Electronics  
3 Sim'yi Sosnnykh str.  
UA-03148 Kyiv  
Tel. 044 / 501 40 45  
Fax 044 / 273 57 49  
E-Mail: [info@benning.ua](mailto:info@benning.ua)

### U.S.A.

Benning Power Electronics, Inc.  
11120 Grader Street  
USA-Dallas, TX 75238  
Tel. 214 5531444  
Fax 214 5531355  
E-Mail: [sales@benning.us](mailto:sales@benning.us)

ISO  
9001

ISO  
14001

SCC

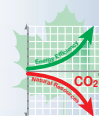

# BENNING